



# Protein Crystallisation

An important method for the determination of protein structures is x-ray analysis of protein crystals. The determination of the three-dimensional structure of proteins has contributed towards major advances in basic research, particularly in the fields of structural genomics and structure-based drug design.

The most commonly used method for the crystallisation of proteins is vapour diffusion which comprises both the sitting drop and hanging drop methods (Fig. 1a and Fig. 1b). One drop of protein solution is mixed with one drop of reagent solution and incubated together with a larger volume of reagent solution in a sealed well. Concentration gradients between the sample drop and the reservoir solution are balanced out by diffusion, which induces the crystallisation process if the correct conditions have been selected.

The microbatch method (Fig. 1c) in which the sample drop is covered with oil is also widely used, and in this technique the choice of oil determines the rate of diffusion of the water in the sample drop through the oil.

Numerous factors affect the crystallisation of proteins. Since the optimal crystallisation conditions generally cannot be predicted, a large number of attempts is often necessary in order to determine and optimise the appropriate conditions. Protein crystallisation therefore still represents a major bottleneck in structure analysis. The use of high-throughput technologies, such as pipetting robots and standardised microplates, makes it possible to test a large number of crystallisation conditions in a short period of time and with relatively small amounts of protein. The **CrystalStar™** product range from Greiner Bio-One is a family of crystallisation plates and accessories designed specifically for high-throughput crystallisation.

### Format

We place great value on the suitability of our protein crystallisation plates for use with automated systems. Therefore, with the exception of Terasaki plates, all crystallisation plates have a footprint conforming to the ANSI 1-2004 standard. For further information please visit our website: [www.gbo.com/bioscience/technical\\_information](http://www.gbo.com/bioscience/technical_information)

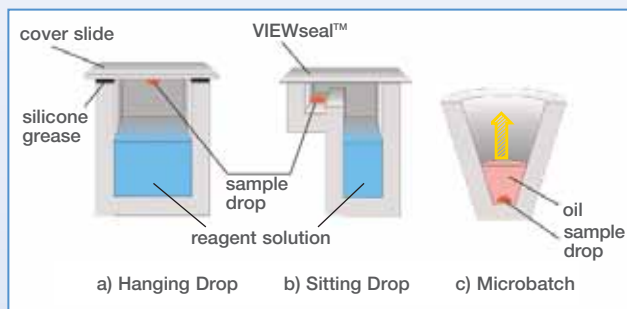

**Figure 1:** Crystallisation methods  
 a) Hanging Drop b) Sitting Drop c) Microbatch



### Barcode Labelling

Customer-specific barcode labelling is available on request for all crystallisation plates, with the exception of Terasaki plates.

### Material

All Greiner Bio-One protein crystallisation plates, with the exception of the LBR plates (see below), are made from polystyrene. This is characterised by high clarity and excellent optical properties.

### Hydrophobic Plates

Plates with a hydrophobic surface are particularly well suited for nanolitre crystallisation of membrane proteins. The surface properties of hydrophobic plates efficiently counteract the spreading of detergent-containing drops, respectively of drops with surfactant precipitants, such as MPD (Fig. 2). Moreover, the meniscus of the screening solution in the reservoir is substantially reduced, so that contaminations through creeping of the screening solution into the crystallisation well are avoided.

### LBR Plates

LBR (low birefringence) plates are specifically designed for the use of polarised light. LBR plates for sitting drop applications are made from polyolefin which is characterised by very low birefringence in comparison with polystyrene plates (Fig. 3). Extreme transparency, high chemical resistance and low water absorption are further characteristics of LBR plates.

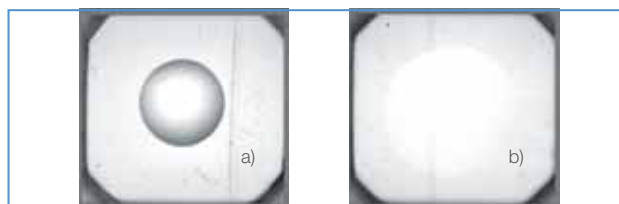

Figure 2: Comparison of (a) CrystalQuick™Plus (hydrophobic surface) and (b) CrystalQuick™ standard. Images of 100 nl drops containing 50 mM n-Octyl-Glucoside are courtesy of Karl Harlos, The Wellcome Trust Centre for Human Genetics, Oxford, UK.

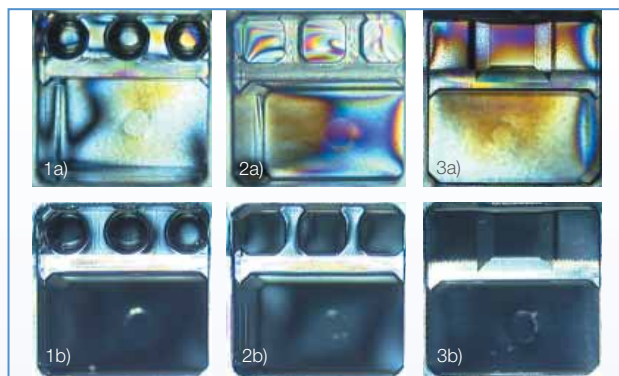

Figure 3: CrystalQuick™ plates in polarised light: (a) Standard versions with strong birefringence, (b) LBR versions with lower birefringence. (1) CrystalQuick™ RW (2) CrystalQuick™ SW (3) CrystalQuick™ LP



Further information on protein crystallisation → **Forum No. 7: Advanced high-throughput platforms for protein crystallisation** (F073 016)

Cat.-No.	Description	Number of sample wells	Number of reservoirs	Special features
<b>Vapour Diffusion</b>				
662 150	ComboPlate™	-	24	-
662 050	ComboPlate™	-	24	pre-greased
609 101	CrystalQuick™ SW (Square Wells)	288	96	-
609 801	CrystalQuick™ SW (Square Wells)	288	96	LBR
609 130	CrystalQuick™ Plus SW (Square Wells)	288	96	hydrophobic
609 830	CrystalQuick™ Plus SW (Square Wells)	288	96	LBR, hydrophobic
609 120	CrystalQuick™ RW (Round Wells)	288	96	-
609 820	CrystalQuick™ RW (Round Wells)	288	96	LBR
609 171	CrystalQuick™ LP (Low Profile)	96	96	-
609 871	CrystalQuick™ LP (Low Profile)	96	96	LBR
609 180	CrystalQuick™ Plus LP (Low Profile)	96	96	hydrophobic
<b>Microbatch</b>				
653 102	Terasaki Plate	60	-	-
654 102	Terasaki Plate	72	-	-
673 170	IMP@CT™ Plate	96	-	-
790 801	IMP@CT™ Plate	1536	-	LBR
<b>Accessories</b>				
676 070	VIEWseal™	-	-	-
676 040	AMPLIseal™	-	-	-
662 145	CrystalBridge™	-	1	-
501 870	Coverslip, 18 mm ø, thickness 2 (0.19 - 0.22 mm)	-	-	glass, siliconised
503 870	Coverslip, 22 mm ø, thickness 2 (0.19 - 0.22 mm)	-	-	glass, siliconised
503 850	Coverslip, 22 mm ø, thickness 5 (0.5 - 0.6 mm)	-	-	glass, siliconised

Table 1: Overview of CrystalStar™ crystallisation plates and accessories.

# Vapour Diffusion Applications

## 96 Well CrystalQuick™ Plates for Sitting Drop Applications

In cooperation with the Genomics Institute of the Novartis Research Foundation (GNF) in San Diego (USA), the Max-Planck Institute (MPI) and the Protein Structure Factory (PSF) in Berlin, Greiner Bio-One has developed a family of 96 well crystallisation plates for sitting drop applications. Each of the 96 reservoirs contains an elevated platform with either one or three crystallisation wells. The plates are optimised for sealing with VIEWseal™ adhesive film (→ p. 12 | 4). The external dimensions and tolerances of the CrystalQuick™ plates are suitable for automated applications. All CrystalQuick™ plates are available in an LBR version for the use of polarised light. Plates with a hydrophobic surface can be found in the table under CrystalQuick™ Plus plates.

### CrystalQuick™ SW (Square Wells Fig. 1, Fig. 2)

With three crystallisation wells per reservoir, CrystalQuick™ SW makes it possible to test 288 samples per plate. The flat bottom of the wells provides for good optical properties. The maximum volume of the crystallisation drops is 4 µl (US Patent No. 7005008 B2).

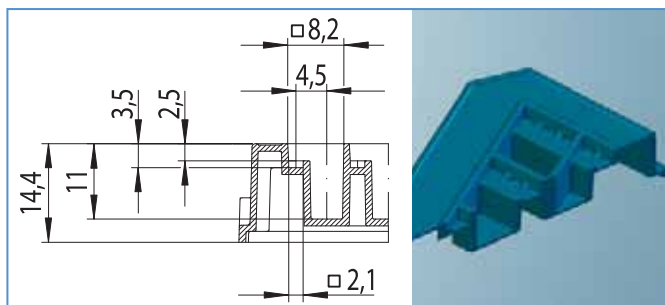

Figure 1: Well profile, CrystalQuick™ SW

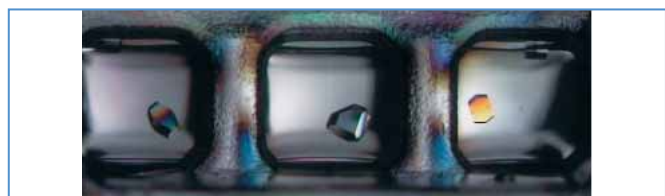

Figure 2: Crystallisation of lysozyme in CrystalQuick™ SW

### CrystalQuick™ RW (Round Wells Fig. 3, Fig. 4)

With three round crystallisation wells per reservoir, CrystalQuick™ RW makes it possible to test 288 samples per plate. The bottom of the crystallisation wells is concave. The maximum volume of the crystallisation drops is 1.9 µl.

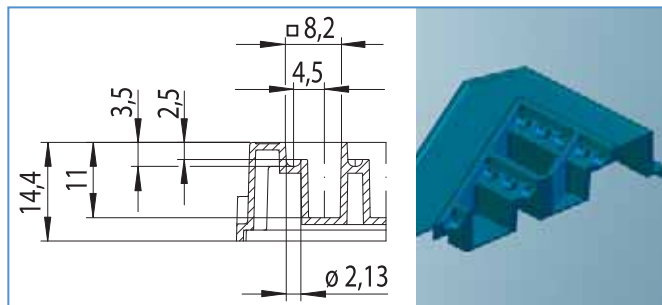

Figure 3: Well profile, CrystalQuick™ RW

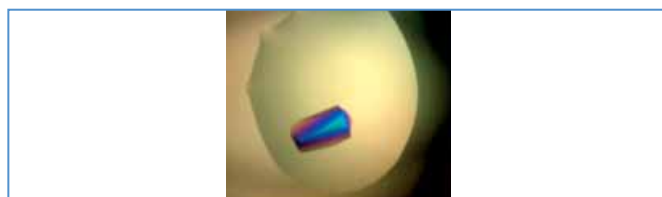

Figure 4: Protein crystal in CrystalQuick™ RW, the image was kindly supplied by B. Blattmann, NCCR Structural Biology, Switzerland

### CrystalQuick™ LP (Low Profile Fig. 5, Fig. 6)

CrystalQuick™ LP (low profile) crystallisation plates are characterised by excellent optical properties. Crystal harvesting is made easier by the angled walls of the crystallisation wells. The low profile reduces space requirements for storage.

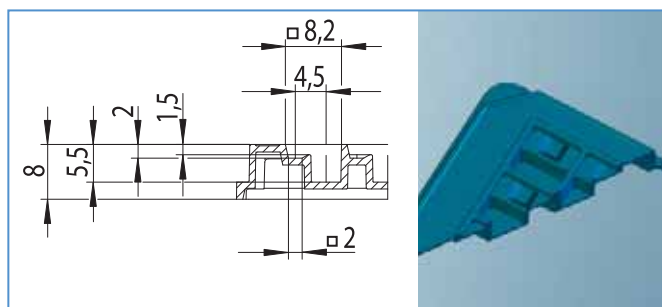

Figure 5: Well profile, CrystalQuick™ LP

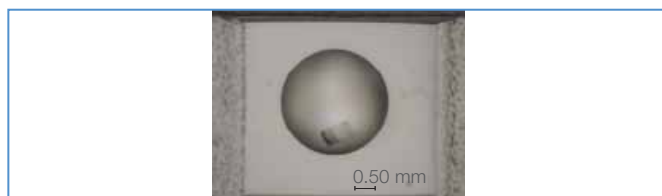
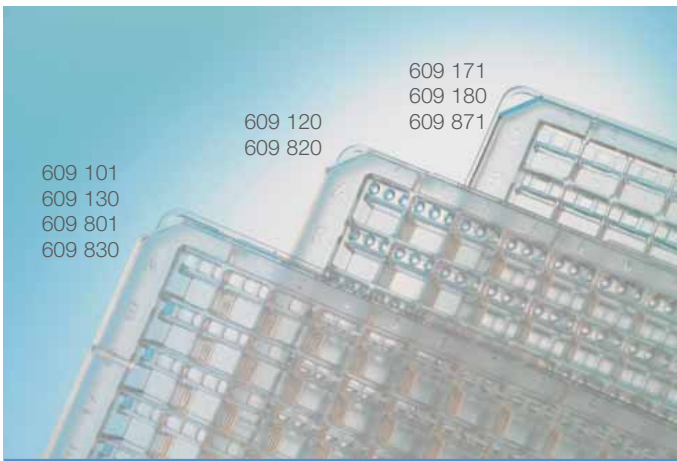

Figure 6: Crystallisation of lysozyme in CrystalQuick™ LP, RoboDesign International Inc., Carlsbad (USA)

**!** All CrystalQuick™ plates feature an alphanumeric well coding.

- 1 Cell/Tissue Culture
- 2 HTS-Microplates
- 3 Immunology/HLA
- 4 Microbiology/Bacteriology
- 5 Tubes/Multi-Purpose Beakers
- 6 Liquid Handling
- 7 Molecular Biology
- 8 Protein Crystallisation
- 9 Separation
- 10 Biochips/Microfluidics
- 11 Cryo-Technics
- 12 Lids/Sealers/CapMats
- 13 Reaction Tubes/Analyser Cups
- 14 Accessories



## 96 Well CrystalQuick™ 96 Well CrystalQuick™ Plus

↳ Lids and Sealers p. 12 | 2 ff.

- Crystallisation plates for sitting drop applications with different well profiles and material properties
- Alphanumeric well coding

### CrystalQuick™

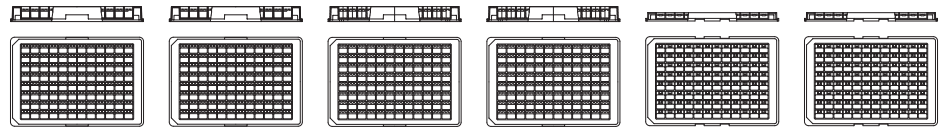

Cat.-No.	609 101	609 801	609 120	609 820	609 171	609 871
Description	CrystalQuick™	CrystalQuick™	CrystalQuick™	CrystalQuick™	CrystalQuick™	CrystalQuick™
Material properties	standard	LBR	standard	LBR	standard	LBR
Well profile	square (SW)	square (SW)	round (RW)	round (RW)	square (LP)	square (LP)
Well bottom	flat	flat	concave	concave	flat	flat
Well per reservoir	3	3	3	3	1	1
Max. well volume [µl]	4.1	4.1	1.9	1.9	3.9	3.9
Volume per reservoir [µl]	320	320	320	320	140	140
Height [mm]	14.4	14.4	14.4	14.4	8.0 (low profile)	8.0 (low profile)
Quantity per bag/case	10/40	10/40	10/40	10/40	20/80	20/80

### CrystalQuick™ Plus

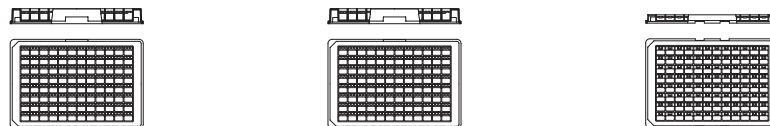

Cat.-No.	609 130	609 830	609 180
Description	CrystalQuick™ Plus	CrystalQuick™ Plus	CrystalQuick™ Plus
Material properties	hydrophobic	LBR, hydrophobic	hydrophobic
Well profile	square (SW)	square (SW)	square (LP)
Well bottom	flat	flat	flat
Well per reservoir	3	3	1
Max. well volume [µl]	4.1	4.1	3.9
Volume per reservoir [µl]	320	320	140
Height [mm]	14.4	14.4	8.0 (low profile)
Quantity per bag/case	10/40	10/40	20/80



## 24 Well ComboPlate™, CrystalBridge™ and Coverslips



### 24 Well ComboPlate™, CrystalBridge™ and Coverslips

↳ Lids and Sealers p. 12 | 2 ff.

- Universal 24 well crystallisation plate
- Pre-greased plates available
- Siliconised coverslips available

#### ComboPlate™

The ComboPlate™ was developed as universal platform for crystallisation in the 24 well format in cooperation with Hampton Research (Fig. 8). Clear polystyrene in combination with a flat, distortion-free bottom offers excellent optical properties. A flattened, raised ring around each well reduces the risk of cross-contamination and makes it possible to seal the wells with silicone grease and coverslips (ø 18 mm) or VIEWseal™ sealer (Cat.-No. 676 070). A slightly raised lid protects the coverslips and sealer during transportation and storage.

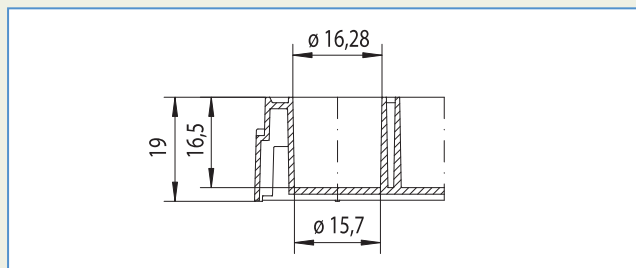

Figure 8: Well profile, 24 well ComboPlate™

**!** The ComboPlate™ is also available pre-greased or in an LBR version for use with polarised light. As an accessory for the ComboPlate™ Greiner Bio-One offers siliconised coverslips (round, ø 18 mm) (Fig. 9). Siliconised coverslips for Linbro plates (round, ø 22 mm) can also be found in our product line.



Figure 9: ComboPlate™ sealed with coverslips

#### CrystalBridge™

Sitting drop experiments are possible using the CrystalBridge™ inserts which fit exactly into the wells of the ComboPlate™. The well with a concave bottom integrated into the CrystalBridge™ has a volume of 45 µl. If necessary, CrystalBridge™ inserts can be transferred to another well during the course of an experiment.

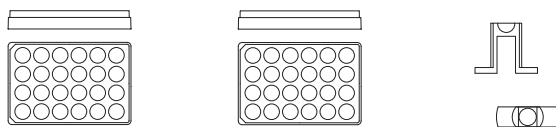

Cat.-No.	662 150	662 050	662 145
Description	ComboPlate™	ComboPlate™	CrystalBridge™
Material properties	-	pre-greased	-
Format	24 well	24 well	1 well
Well bottom	flat	flat	concave
ø Well [mm]	16.3	16.3	4.6
Max. well volume [µl]	3300	3300	45
Lid	+	+	-
Quantity per bag/case	6/24	6/24	250
Cat.-No.	501 870	503 870	503 850
Description	round coverslips	round coverslips	round coverslips
Material properties	siliconised glass	siliconised glass	siliconised glass
ø [mm]	18	22	22
Thickness [mm]	0.19 - 0.22	0.19 - 0.22	0.5 - 0.6
Quantity per box/case	100/1000	100/1000	100/1000

1 Cell/ Tissue Culture  
2 HTS- Microplates  
3 Immunology/ HLA  
4 Microbiology/ Bacteriology  
5 Tubes/Multi- Purpose Beakers  
6 Liquid Handling  
7 Molecular Biology  
8 Protein Crystallisation  
9 Separation  
10 Biochips/ Microfluidics  
11 Cryo-Techniques  
12 Lids/Sealers/ CapMats  
13 Reaction Tubes/ Analyser Cups  
14 Accessories

# Microbatch under Oil Applications

## 60 Well and 72 Well Terasaki Plates



### 60 Well / 72 Well Terasaki Plates

Surface-treated Terasaki Plates p. 3 | 11

#### 60 Well and 72 Well Terasaki Plates

Terasaki plates are widely used for microbatch crystallisation. The crystallisation drop is localised centrally as a result of the conical well geometry, and the flat well bottom makes for optimal monitoring (Fig. 10). The rim of the Terasaki plates makes it possible to fill all of the wells with oil at the same time. As a result of the small external dimensions and the low profile of the Terasaki plates, the space required for storage is relatively small. Terasaki plates are supplied with a fitting lid.

The plates are also supplied with surface treatment (→ p. 3 | 11). The treatment of the plates influences the sticking of the crystallisation drop to the bottom of the well.

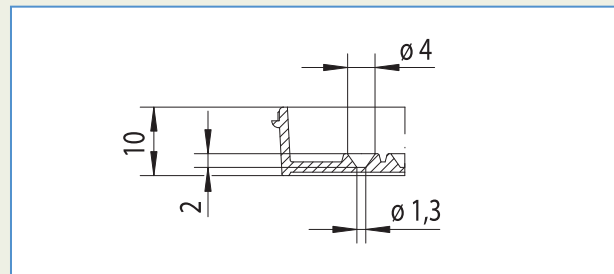

Figure 10: Well profile, Terasaki plate



Cat.-No.	653 102	654 102
Description	Terasaki plate	Terasaki plate
Format	60 well	72 well
Well profile	conical	conical
Well bottom	flat	flat
ø Well bottom [mm]	1.3	1.3
Working volume per well [µl]	10	10
Max. volume per well [µl]	11.5	11.5
Length [mm] x width [mm] x height [mm]	83.3 x 58 x 10	83.3 x 58 x 10
Surface treatment	-	-
Quantity per bag/case	10/580	10/270

1 Cell/  
Tissue Culture

2 HTS-  
Microplates

3 Immunology/  
HLA

4 Microbiology/  
Bacteriology

5 Tubes/Multi-  
Purpose Beakers

6 Liquid  
Handling

7 Molecular  
Biology

8 Protein  
Crystallisation

9 Separation

10 Biochips/  
Microfluidics

11 Cryo-  
Technics

12 Lids/Sealers/  
CapMats

13 Reaction Tubes/  
Analyser Cups

14 Accessories

## 96 Well and 1536 Well IMP@CT™ Plate

### IMP@CT™ Plates

IMP@CT™ plates are microplates for high-throughput crystallisation, specially designed for microbatch applications under oil. The IMP@CT™ crystallisation plates are characterised by conical wells with a flat bottom. The conical form of the wells has the effect of centrally localising the crystallisation drops, even when small sample volumes are used. The flat well bottom makes for optimal monitoring of the crystallisation samples. An appropriate lid is available.

### 96 Well IMP@CT™ Plate (Fig. 11)

The 96 well IMP@CT™ plate was developed by Greiner Bio-One in cooperation with Hampton Research (USA) and Allan D'Arcy. The double rim of the plates means that the wells can be filled separately or together with oil. Filling the double rim of the IMP@CT™ plates with an aqueous gel makes it possible to control water evaporation from the crystallisation drops.

### 1536 Well IMP@CT™ LBR Plate (Fig. 12)

The 1536 well IMP@CT™ plate was developed in cooperation with the Hauptman-Woodward Medical Research Institute in Buffalo (USA) for use in automated high-throughput systems. The optimised well geometry means that even crystallisation drops with a very small volume are localised at the centre of the wells. Smooth, flat well bottoms provide optimum conditions for monitoring and evaluating crystallisation samples. The 1536 well IMP@CT™ LBR plate is suitable for use in polarised light.

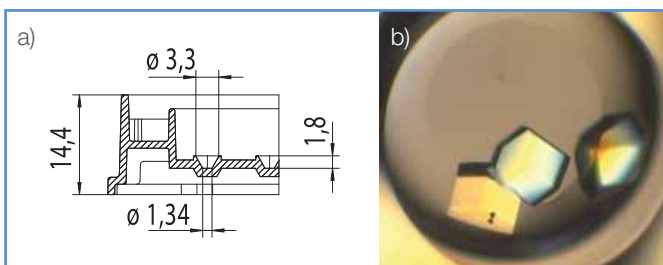

Figure 11a: Well profile, 96 well IMP@CT™ plate  
Figure 11b: Protein crystals in the 96 well IMP@CT™ plate

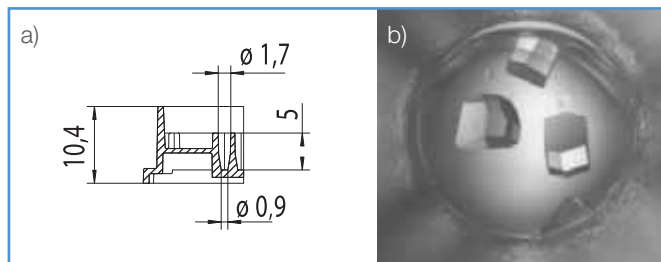

Figure 12a: Well profile, 1536 well IMP@CT™ plate  
Figure 12b: Crystallisation of lysozyme in the 1536 well IMP@CT™ plate, with the kind approval of the Hauptman-Woodward Medical Research Institute, Buffalo (USA).



## 96 Well / 1536 Well IMP@CT™ Plate

Lids and Sealers p. 12 | 2 ff.

- Plate for crystallisation under oil



Cat.-No.	673 170	790 801
Description	IMP@CT™	IMP@CT™
Material properties	clear	clear, LBR
Format	96 well	1536 well
Max. well volume [µl]	8.0	10.1
ø Well bottom [mm]	1.34	0.9
Height [mm]	14.4	10.4
Quantity per bag/case	10/40	15/60

1 Cell/ Tissue Culture  
2 HTS- Microplates  
3 Immunology/ HLA  
4 Microbiology/ Bacteriology  
5 Tubes/Multi- Purpose Beakers  
6 Liquid Handling  
7 Molecular Biology  
8 Protein Crystallisation  
9 Separation  
10 Biochips/ Microfluidics  
11 Cryo-Technics  
12 Lids/Sealers/ CapMats  
13 Reaction Tubes/ Analyser Cups  
14 Accessories

# CrystalSlide™

## Micro-channel Platform for Counter Diffusion Crystallography

Greiner Bio-One developed a platform for Counter Diffusion Crystallography in a standard microscope slide format in collaboration with the laboratory of Peter Kuhn, The Scripps Research Institute, La Jolla, CA, USA. The platform features 12 channels (0.1 mm x 0.1 mm x 20 mm) for counter diffusion experiments. Filling reservoirs are optimised for the use of

Greiner Bio-One crystal tips (→ p. 6 | 5). Automated handling is facilitated by housing four slides in a slide holder with standard microplate footprint. Due to its design and material properties CrystalSlide™ is well suited for in situ X-ray analysis and crystal analysis with polarised light or UV-light (Fig. 13).

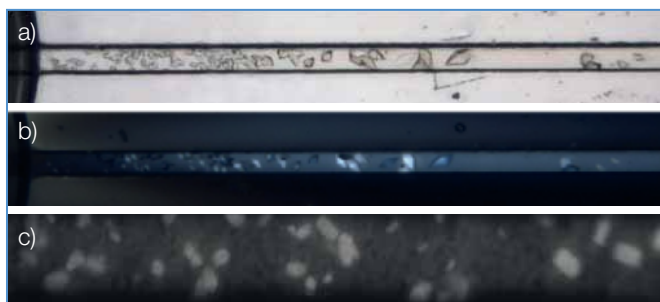

**Figure 13:** Bright field (a), polarised (b) and UV-fluorescence (c) images of protein crystals in CrystalSlide™. Images are courtesy of Peter Kuhn, The Scripps Research Institute, La Jolla, CA, USA.

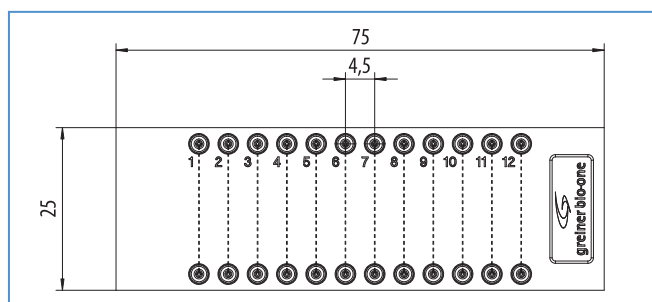

**Figure 14:** Schematic drawing of CrystalSlide™

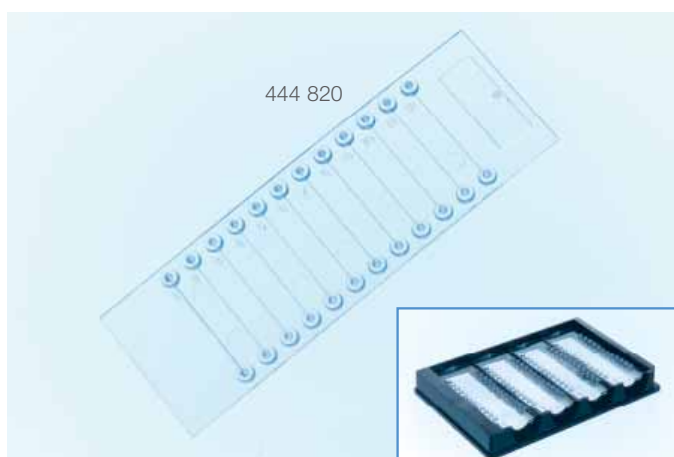

### CrystalSlide™

- ▶ Crystal Pipette Tips p. 6 | 5
- ▶ CrystalSlide™ User Guide (order no. F073 053)

- Micro-channel platform for counter diffusion crystallography
- Slide holder available on request



Cat.-No.	444 820
Description	CrystalSlide™
Material properties	LBR, UV-transmissible, X-ray transmissible
Slide dimensions (L x W) [mm]	75 x 25
Channel dimensions (L x W x H) [mm]	20 x 0.1 x 0.1
Number of channels per slide	12
Channel volume [µl]	200
Quantity per box/case	4/20